

# LIVE PANEL







The patented LivePanel system is a unique and innovative living wall system in the world of vertical greenery. These green walls, filled with real plants, are increasing in popularity, contributing to the environment and creating a healthy indoor climate.

## MODULAR GREEN WALL SYSTEM

The LivePanel system transforms bare walls into warm vibrant displays, instantly. LivePanel is a modular green wall system with interchangeable plant cassettes. The cassettes have slots into which plants are placed. Each row of plant cassettes is placed in a gutter profile that also serves as a water reservoir. The plants absorb water from the reservoir by means of capillary action. The system can be installed against both new and existing walls.

## VERTICAL GREEN

LivePanel can be used in a variety of vertical green scenarios. This allows the customer complete freedom when designing their own green wall, as well as the choice of plants. LivePanel is easy to install on various types of walls. The living wall brings an extra dimension to a room, is soothing yet striking on the eye, and is a real head-turner for any interior.

## LIVEPANEL MATERIALS



**Cassettes:** The cassettes are made of breathable Expanded Polypropylene (EPP) material on the front side, Polypropylene (PP) on the backside. The cassette is fitted with microfibre textile with capillary action consisting of 80% polyester and 20% polyamide. Returned cassettes are fitted with a new microfibre textile on our production site and reused.

**Fire-retardant cassettes:** The cassettes are also available in grey EPP with fire-retardant. The green wall complies with fire classification B-s2, d0.

**Gutter profiles and mounting materials:** The aluminium extruded gutter profiles are made of alloy AL 6063 T5. The profiles are black anodised. Because of this, the profiles have optimal corrosion resistance and can be used outdoors. The mounting material for installing the profiles is of A2 stainless steel quality. The profiles are provided with end and transit caps made of fiberglass polyamide that is attached to the profile with self-tapping screws. Between the end caps and profiles, there is an EPDM rubber seal. The transit caps are fitted with hose tails where a plastic hose is mounted with stainless steel hose clamps.



**Planting:** The plants used in the pre-cultivated cassettes in the LivePanel system are grown at the Dartplant production site under the "On the way to PlanetProof" certification. This independent certification proves that the plants for the LivePanel green wall have been produced more sustainably and are therefore a better choice for nature, climate and animals. The online Mobilane PlantGuide gives an overview of selected plant species that are recommended for planting on the LivePanel wall.





# UNIQUE FEATURES

Choose manual or automatic irrigation system

Available in any size

Economical water consumption and no waste

Space saving and slim system

Modular system

Interchangeable plant cassettes

Easy and quick installation

Allows freedom in design and plant choice

Fully recyclable



# BENEFITS

Vertical greenery takes up little space

Improves the indoor climate and air quality

Helps increase concentration, productivity and general well-being

Improves the acoustics in a room

Insulating and sound-dampening effects

Lowers stress levels



# INSTALLATION



For the indoor green wall system LivePanel, it can be chosen for watering the green wall manually or by means of an irrigation system. For relatively big walls, automatic watering through an irrigation system is advised. Mobilane works with a network of dealers where dealers also offer installation and a maintenance contract.

## PROFILES AND CASSETTES

In most cases, the installation can be directly fitted to any back wall by means of the supplied fasteners; as long as the profiles hang level. The correct distance between them is shown on the supplied building plan specification for the project in question, this must be adhered to. The irrigation system is then connected and activated, after which the cassettes (with planting) can be placed on the profiles.

- The maximum profile length is 520 cm excluding the end caps. Larger walls are therefore made up of a series of profiles, placed next to each other.
- Both the profiles and the (optional) frame are easy for the installer to customize in the required size. The cassettes are flexible and can be cut horizontally and vertically by using the indicated sawing lines at the back side of the cassettes. In the calculations it is necessary to take into account tolerances in the aluminium profiles.
- Modular system based on plant cassettes of 40 x 40 cm. Weight including plants 35kg-40kg/m<sup>2</sup>.
- An overflow / drainage should always be provided for internal applications.
- If LivePanel is applied to the inside of outer walls (façade) which are not sufficiently isolated ( $R_c = 4.5 \text{ m}^2 \text{ K/W}$ ), an XPS insulation with a thickness of at least 20 mm has to be fitted at the inner wall. Both these plates as well as the intermediate seams need to be completely air-tight and vapour-inhibiting. This ensures a thermal shield of the outer wall thereby reducing the risk of fungal attack and condensation.
- Choice of plants is dependent on where the facade is installed. The surface orientation is important so the amount of sun exposure and shade that a facade receives is taken into account. Depending on this, a planting plan is made.

## PLACING AND WATERING

	LivePanel
Indoor	●
Outdoor	
<b>Watergift</b>	
Manual	●
Tank	●
Irrigation system	●

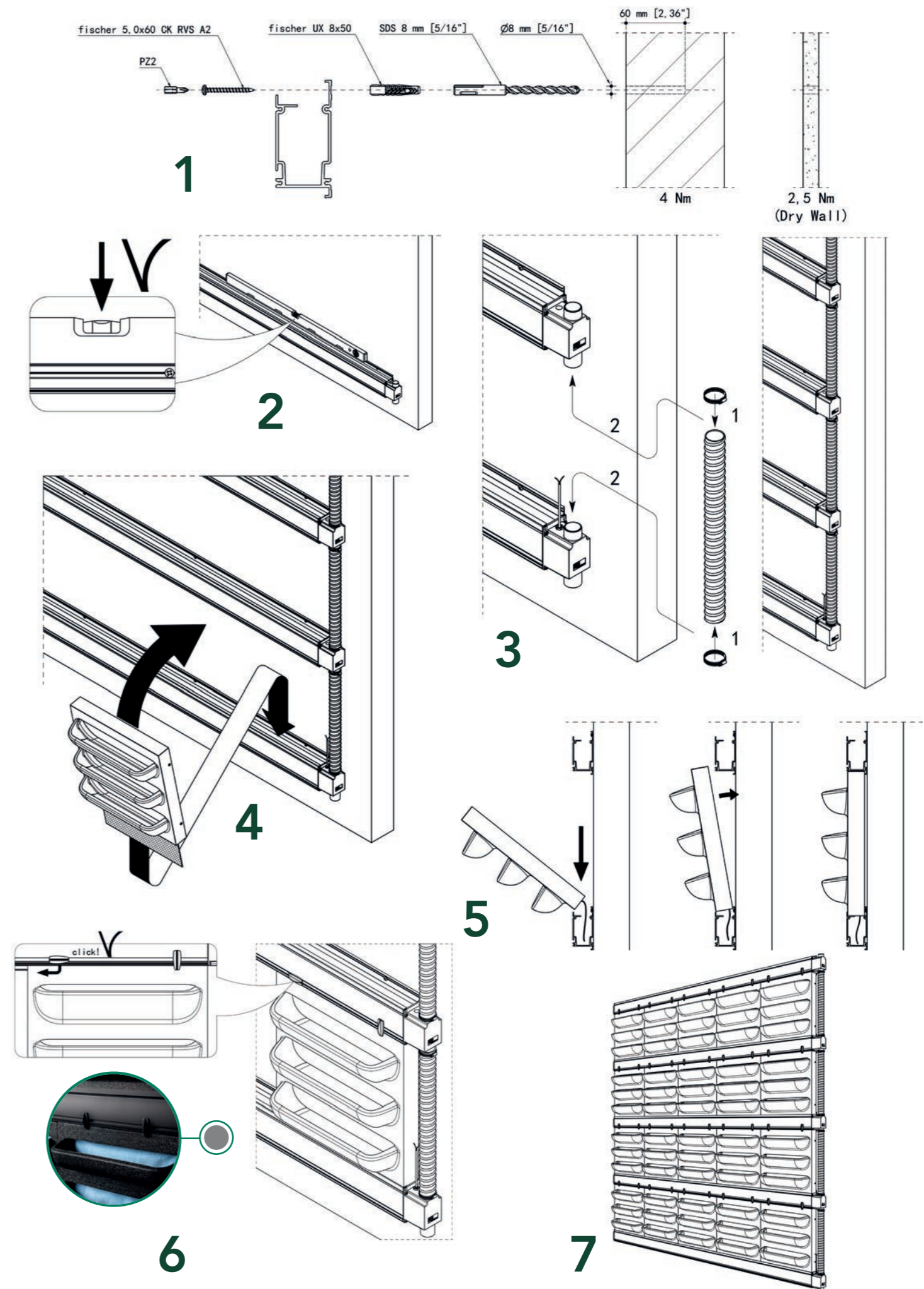



# MAINTENANCE



## MAINTENANCE

The maintenance of a green wall consists of pruning, replacing bad plants, identifying and controlling any diseases and pests. The frequency of maintenance depends on the types of plants, season, and the associated growth of the planting. Maintenance of a green wall is very important for ensuring optimum appearance and a healthy green wall.

### 1. PRUNING

For the protection of the green wall, it is essential that the wall is well maintained and the planting is pruned. The wall should be pruned about twice a year, depending on plant type. By pruning the wall, new growth is stimulated. The planting in the green wall will become full and retain its fresh appearance. The green wall is pruned by means of pruning shears.



## 2. IRRIGATION SYSTEM CHECK

The irrigation system should be checked regularly. Mobilane offers a suitable irrigation system with an integrated nutrient supply for every green wall. Every green wall is different and requires appropriate adjustment. A lot of variables are under constant monitoring to ensure that the green wall has a vital appearance all year round.

## 3. NUTRITION

Non-ground-based systems such as Mobilane's LivePanel, having no connection to the ground, require a permanent and responsive needs-adapted water and nutrition supply. The LivePanel green wall system uses an irrigation system in which continuous nutrition is added to the water to give the green wall the perfect appearance and keep plants healthy. When watering manually, fertilizer should be added to the irrigation water.





# REFERENCES AND APPLICATIONS



CONFERENCE ROOM



ENTRANCE HALL

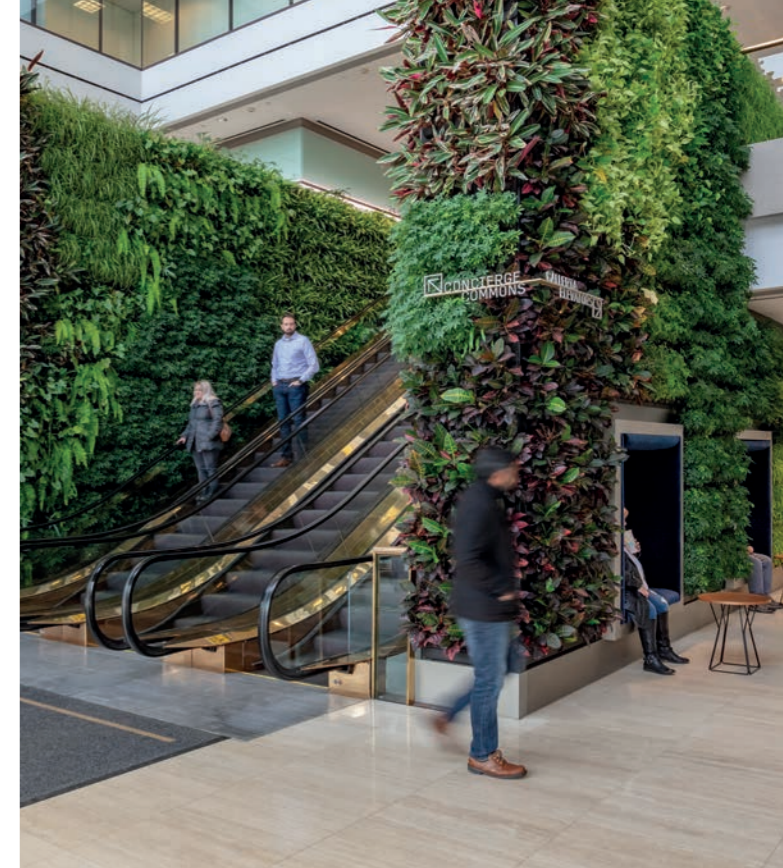

RESTAURANT

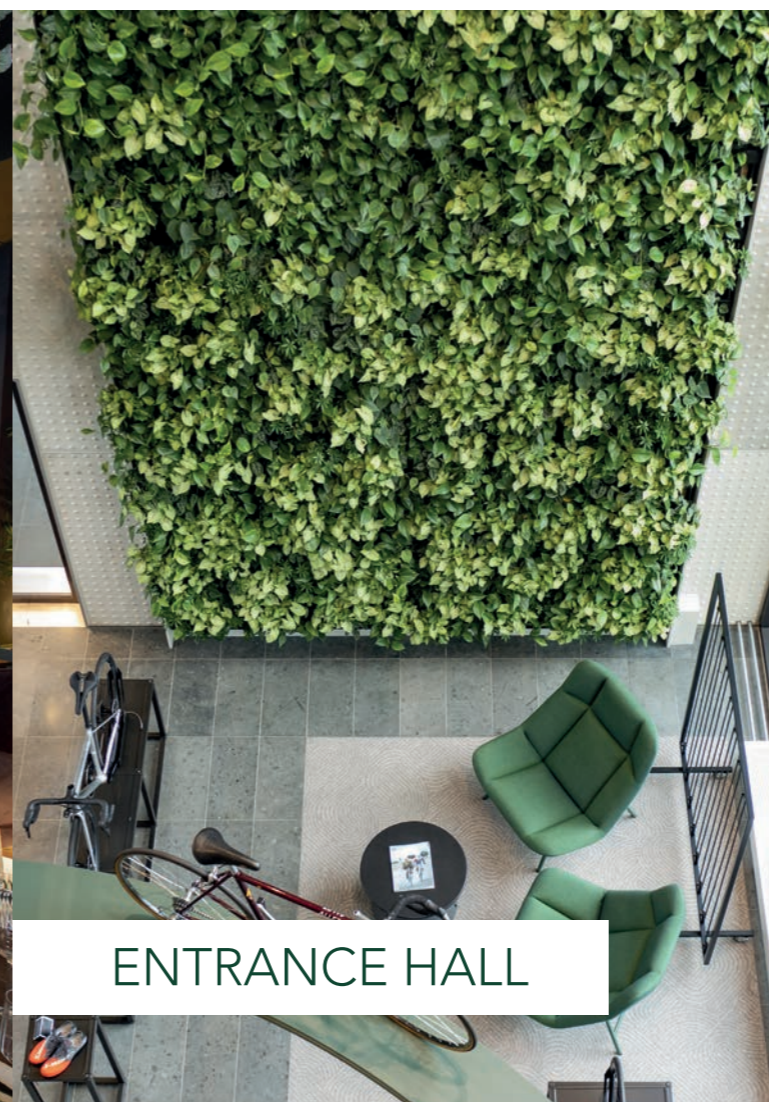

ENTRANCE HALL







OFFICE



OFFICE



HOTELS, RESTAURANTS AND CAFES



ENTRANCE HALL





# CASE STUDY



## PROJECT INFORMATION

Since the LivePanel Indoor system is modular and customizable, a green wall can be created in most difficult situations. The green wall shown above has been installed in a conference room with a surface of 30 m<sup>2</sup>. The green wall has been installed on a curved wall.

## GREEN WALL SYSTEM

The green wall is realised with the LivePanel Indoor green wall system from Mobilane. In the building, there is a technical room where the irrigation unit is installed. From here, the green wall is automatically provided with water and nutrition. The planting can be pregrown so you have a fully grown green wall immediately.

**CLIENT :** Darthuizer Groep  
**ARCHITECT:** Equilibre-interiors  
**CONTRACTOR:** Mobicare  
**YEAR OF CONSTRUCTION :** 2019  
**LOCATION :** Bommel, NL

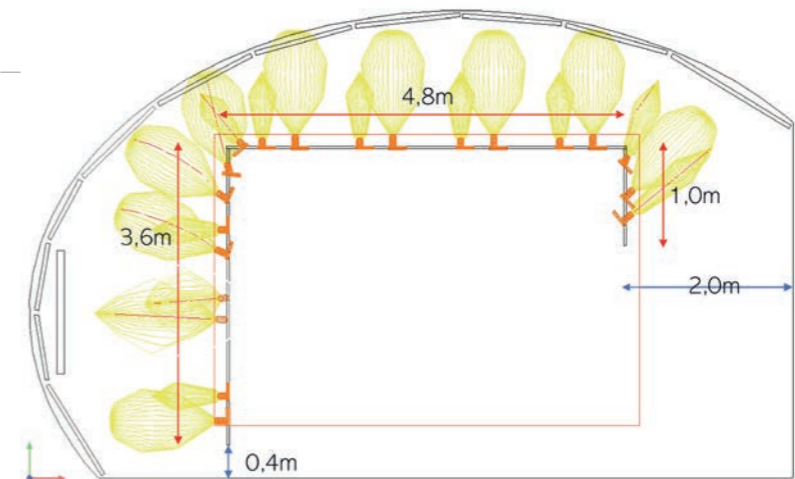
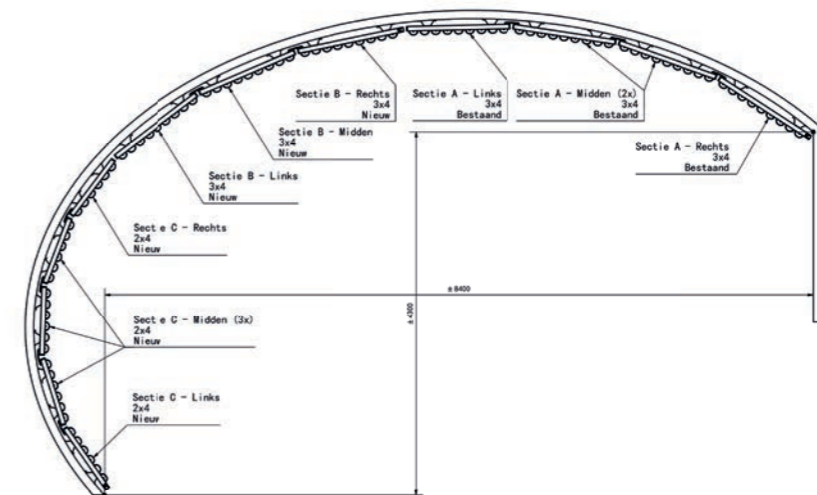



# CALCULATION MODEL

		Sqm																									
Height in CM	20	983,0	4,7	8,7	12,6	16,6	20,5	24,5	28,4	32,3	36,3	40,2	44,2	48,1	52,1	56,8	60,8	64,7	68,7	72,6	76,6	80,5	84,4	88,4	92,3	96,3	100,2
	19	934,5	4,5	8,3	12,0	15,8	19,5	23,3	27,0	30,7	34,5	38,2	42,0	45,7	49,5	54,0	57,8	61,5	65,3	69,0	72,8	76,5	80,3	84,0	87,8	91,5	95,3
	18	886,0	4,3	7,8	11,4	14,9	18,5	22,0	25,6	29,2	32,7	36,3	39,8	43,4	46,9	51,2	54,8	58,3	61,9	65,5	69,0	72,6	76,1	79,7	83,2	86,8	90,3
	17	837,5	4,1	7,4	10,8	14,1	17,5	20,8	24,2	27,6	30,9	34,3	37,6	41,0	44,4	48,4	51,8	55,2	58,5	61,9	65,2	68,6	71,9	75,3	78,7	82,0	85,4
	16	789,0	3,8	7,0	10,1	13,3	16,5	19,6	22,8	26,0	29,1	32,3	35,5	38,6	41,8	45,6	48,8	52,0	55,1	58,3	61,5	64,6	67,8	70,9	74,1	77,3	80,4
	15	740,5	3,6	6,6	9,5	12,5	15,5	18,4	21,4	24,4	27,3	30,3	33,3	36,3	39,2	42,8	45,8	48,8	51,7	54,7	57,7	60,7	63,6	66,6	69,6	72,5	75,5
	14	692,0	3,4	6,1	8,9	11,7	14,5	17,2	20,0	22,8	25,6	28,3	24,0	33,9	36,7	40,0	42,8	45,6	48,4	51,1	53,9	56,7	59,5	62,2	65,0	67,8	70,6
	13	643,5	3,1	5,7	8,3	10,9	13,4	16,0	18,6	21,2	23,8	26,3	28,9	31,5	34,1	37,2	39,8	42,4	45,0	47,6	50,1	52,7	55,3	57,9	60,5	63,0	65,6
	12	595,0	2,9	5,3	7,7	10,1	12,4	14,8	17,2	19,6	22,0	24,4	26,8	29,1	31,5	34,4	36,8	39,2	41,6	44,0	46,4	48,7	51,1	53,5	55,9	58,3	60,7
	11	546,5	2,7	4,9	7,0	9,2	11,4	13,6	15,8	18,0	20,2	22,4	24,6	26,8	29,0	31,6	33,8	36,0	38,2	40,4	42,6	44,8	47,0	49,2	51,3	53,5	55,7
	10	498,0	2,4	4,4	6,4	8,4	10,4	12,4	14,4	16,4	18,4	20,4	22,4	24,4	26,4	28,8	30,8	32,8	34,8	36,8	38,8	40,8	42,8	44,8	46,8	48,8	50,8
	9	449,5	2,2	4,0	5,8	7,6	9,4	11,2	13,0	14,8	16,6	18,4	20,2	22,0	23,8	26,0	27,8	29,6	31,4	33,2	35,0	36,8	38,6	40,4	42,2	44,0	45,8
	8	401,0	2,0	3,6	5,2	6,8	8,4	10,0	11,6	13,2	14,8	16,4	18,0	19,7	21,3	23,2	24,8	26,4	28,0	29,7	31,3	32,9	34,5	36,1	37,7	39,3	40,9
	7	352,5	1,7	3,1	4,6	6,0	7,4	8,8	10,2	11,6	13,0	14,5	15,9	17,3	18,7	20,4	21,8	23,2	24,7	26,1	27,5	28,9	30,3	31,7	33,1	34,6	36,0
	6	304,0	1,5	2,7	3,9	5,2	6,4	7,6	8,8	10,0	11,3	12,5	13,7	14,9	16,1	17,6	18,8	20,1	21,3	22,5	23,7	24,9	26,1	27,4	28,6	29,8	31,0
	5	255,5	1,3	2,3	3,3	4,3	5,4	6,4	7,4	8,4	9,5	10,5	11,5	12,5	13,6	14,8	15,8	16,9	17,9	18,9	19,9	21,0	22,0	23,0	24,0	25,1	26,1
	4	207,0	1,0	1,9	2,7	3,5	4,4	5,2	6,0	6,8	7,7	8,5	9,3	10,2	11,0	12,0	12,8	13,7	14,5	15,3	16,2	17,0	17,8	18,7	19,5	20,3	21,1
	3	158,5	0,8	1,4	2,1	2,7	3,3	4,0	4,6	5,3	5,9	6,5	7,2	7,8	8,4	9,2	9,8	10,5	11,1	11,8	12,4	13,0	13,7	14,3	14,9	15,6	16,2
	2	110,0	0,6	1,0	1,5	1,9	2,3	2,8	3,2	3,7	4,1	4,5	5,0	5,4	5,9	6,4	6,8	7,3	7,7	8,2	8,6	9,1	9,5	9,9	10,4	10,8	11,3
	1	61,5	0,3	0,6	0,8	1,1	1,3	1,6	1,8	2,1	2,3	2,6	2,8	3,1	3,3	3,6	3,9	4,1	4,3	4,6	4,8	5,1	5,3	5,6	5,8	6,1	6,3
CASSETTES	CM	47,8	87,9	128,0	168,1	208,2	248,3	288,4	328,5	368,6	408,7	448,8	488,9	529,0	* 1 cm	577,8	617,9	658,0	698,1	738,2	778,3	818,4	858,5	898,6	938,7	978,8	1.018,9
CASSETTES		1	2	3	4	5	6	7	8	9	10	11	12	13		14	15	16	17	18	19	20	21	22	23	24	25
		Width in CM																									

Plants per cassette:	9	Water use approx.:	5L /m <sup>2</sup> / week
Plants per m <sup>2</sup> :	45	Weight:	40 kg / m <sup>2</sup> all-in

To add 1/3 cassette in width = **+14cm**  
 To add 2/3 cassette in width = **+28cm**  
**Add Frame:**  
 Walls <5,2m length = **+ 28,5cm** in width  
 Walls >5,2m length = **+ 20,8cm** in width

To add 1/3 cassette in height = **+ 23,5 cm**  
 To add 2/3 cassette in height = **+ 36 cm**  
**Add Frame:**  
 To add a frame = **+ 18cm** in height

**Installation time indication:**  
 Installation "hardware": 0,5 - 1h /m<sup>2</sup>  
 Planting Cassettes: 1h /m<sup>2</sup>  
 Installation "irrigation unit": 2-3 h /unit

**NOTE : All dimensions are indications. The actual dimensions are defined when the technical drawing is supplied.**





# IRRIGATION UNITS

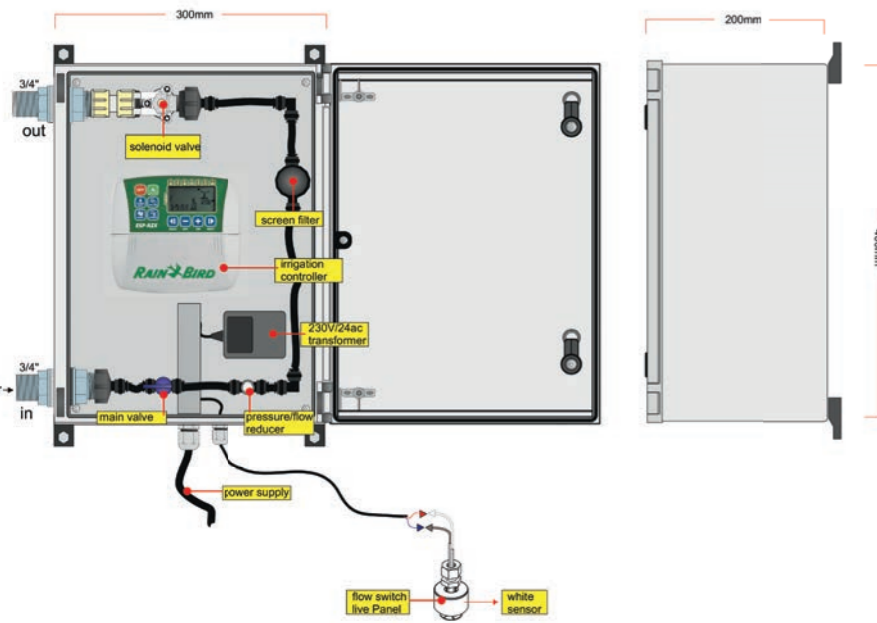

## SPECIFICATIONS GN71

- Huntercontroller controlled
- 1 output 3/4" outer wire
- Sensor WHITE controlled
- Unit size 300 x 200 x 400 mm

## OPTIONS

- Backflow protection NEN EN 1718
- Frost protection

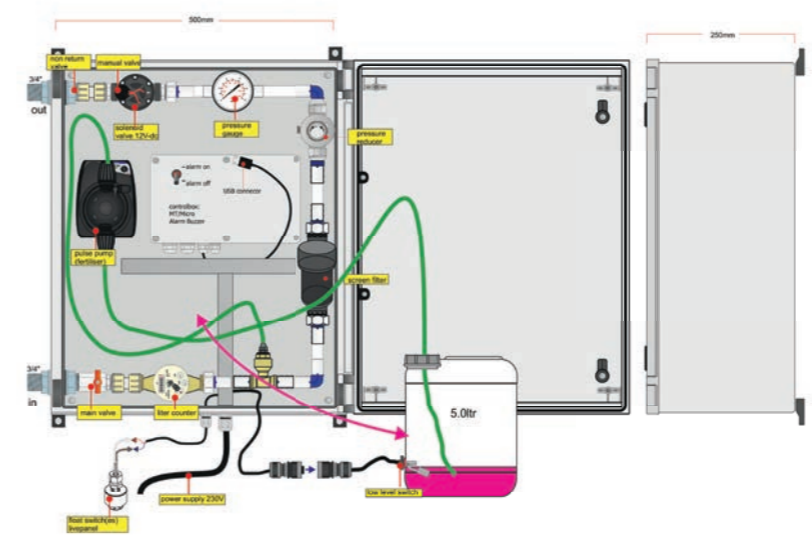

## SPECIFICATIONS GN91

- Automatic injector pump (Aqua)
- Laptop/tablet (USB) controlled
- 1 output 3/4" outer wire
- Sensor BLACK controlled
- Fertilization tank
- Unit size: 500 x 250 x 600 mm

## ALARM OPTIONS\*

1. External alarm
2. SMS alarm integrated
3. SMS alarm external

## OPTIONS

- Breaktank
- Temperature sensor
- Backflow protection NEN EN 1718
- Frost protection

\* The irrigation unit is equipped with a buzzer as standard.

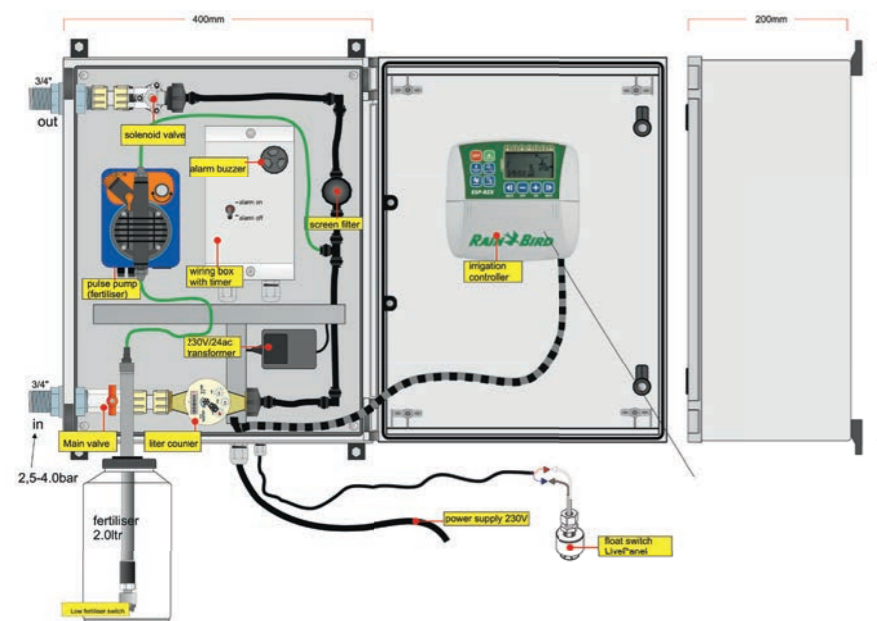

## SPECIFICATIONS GN81

- Automatic injector pump (Aqua)
- Rainbirdcontroller controlled
- 1 output 3/4" outer wire
- Sensor BLACK controlled
- Fertilization tank
- Unit size: 400 x 200 x 500 mm

## ALARM OPTIONS\*

1. External alarm
2. SMS alarm integrated
3. SMS alarm external

## OPTIONS

- Breaktank
- Backflow protection NEN EN 1718
- Frost protection

\* The irrigation unit is equipped with a buzzer as standard.





# TANK



LivePanel TANK is an irrigation system for LivePanel indoor walls. The wall's water supply is stored within the TANK which is placed at the base of the LivePanel. The TANK is filled manually, and the system is connected to the power supply for the pump and timer. The pump drives the water supply from the trough within the tank. As the system does not require connection to a water supply or drainage, it is ultra-efficient in its water consumption.

## WATER SUPPLY

The water supply within the tank is sufficient to irrigate a LivePanel wall for a few weeks. The number of weeks depends on the height of the wall, i.e., the quantity of cassettes on top of each other. The pump should generally be switched on once a week and this is controlled by setting the system's timer (supplied). This allows for irrigation timings outside of office hours. Plant feed should be added to the water supply within the tank.

## DIMENSIONS

The LivePanel TANK can be used for LivePanel Indoor wall with a maximum formation of 10 x 10 cassettes. Each cassette is 40 x 40 cm. The tank is 42 cm high and 17,5 or 30 cm deep. Its width is determined by the width of the LivePanel Indoor wall. For the ultimate finish, an optional matching frame can be placed around the cassettes. This gives the whole a finished and luxurious look



## PARTS



### TANK

Water tank with felt at the bottom. Including removable cover plate consisting of two parts, one of which has a recess for the supply and drain hose. Completely in matt black RAL 9005.



### FRAMING

Matching frame, which can be fastened with Velcro. Completely in matt black RAL 9005.



### TIMER

For switching the pump on and off at any time. Dimensions: 14.6 x 7.6 x 8.2 cm (h x w x d).



### PUMP

12V submersible pump including adapter, power cord and hose clamp.



### DRIP HOSE

5-metre 16 mm Tylen hose with appropriate couplings and drip heads. The drip hose can be secured with tie wraps.



# CAD AND BIM

All CAD and BIM models can be downloaded from the Mobilane website [www.mobilane.com](http://www.mobilane.com) or by scanning the QR-code. CAD and BIM can be used for Revit, IFC, and Civil 3D by architects, engineers and construction professionals (AEC).

**SCAN FOR CAD AND  
BIM MODELS**

