

A

LivePicture

14-0179-01-00
Cassette

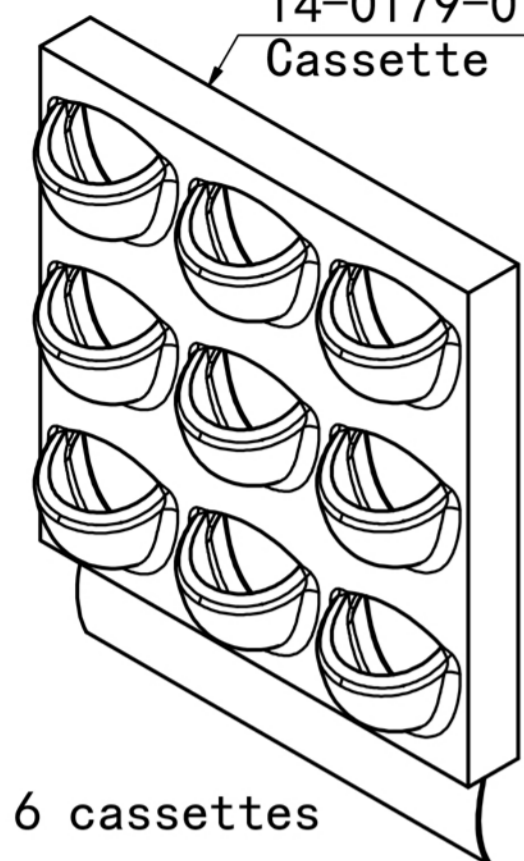

6 cassettes

15-0089-00-01
Funnel

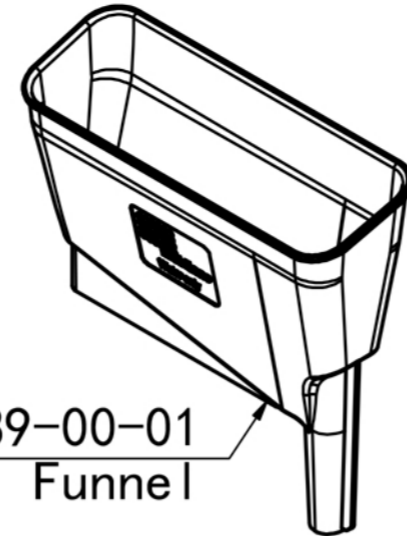

14-0122-10-06
fischer UX 8



12x

6x

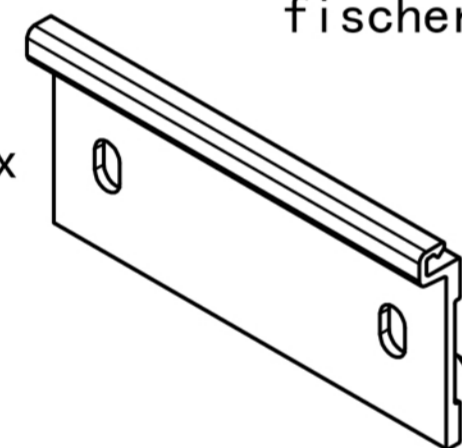

14-0123-01-14
Mounting bracket



12x

14-0122-10-07
fischer 5,0x60 CK RVS A2

14-0123-92-00
Blister

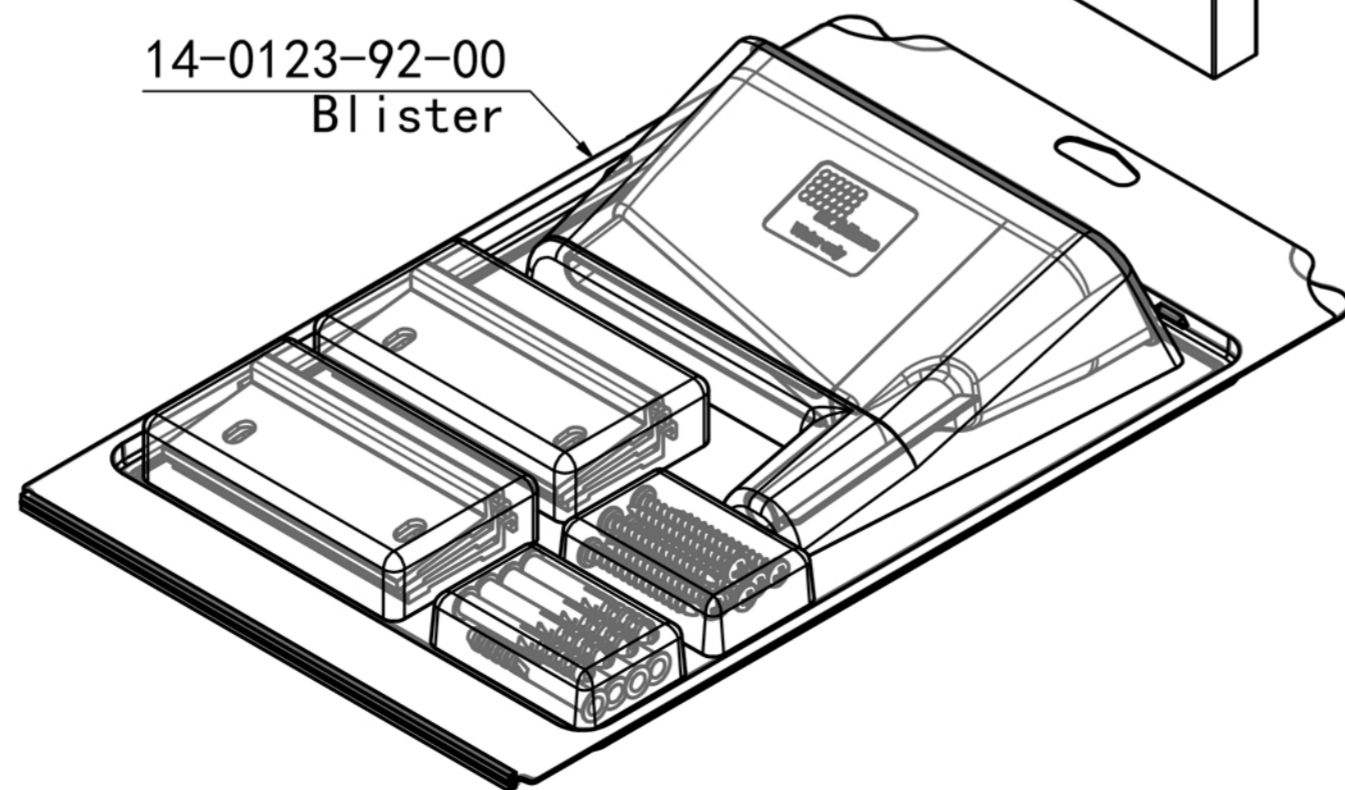

B

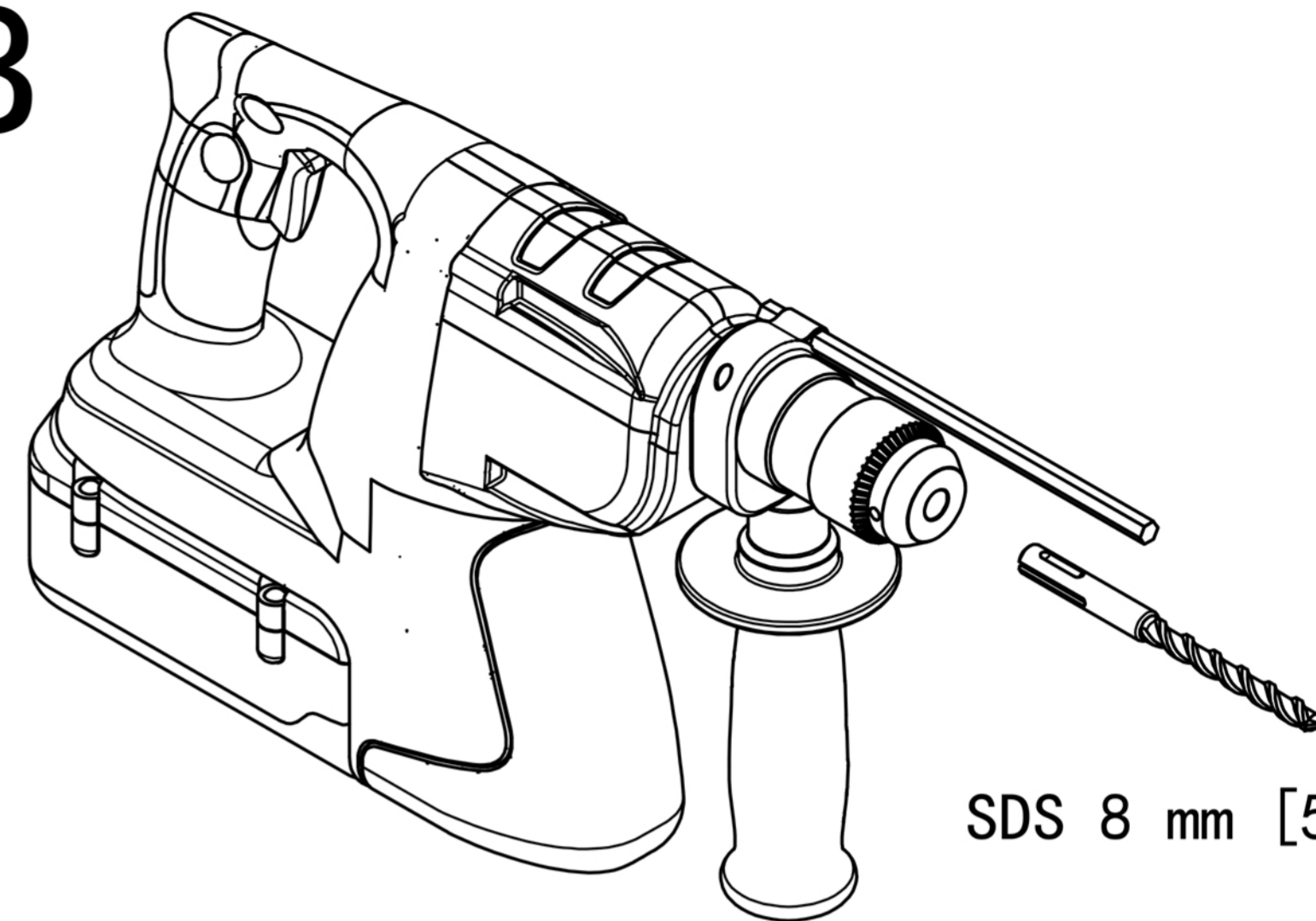

SDS 8 mm [5/16"]

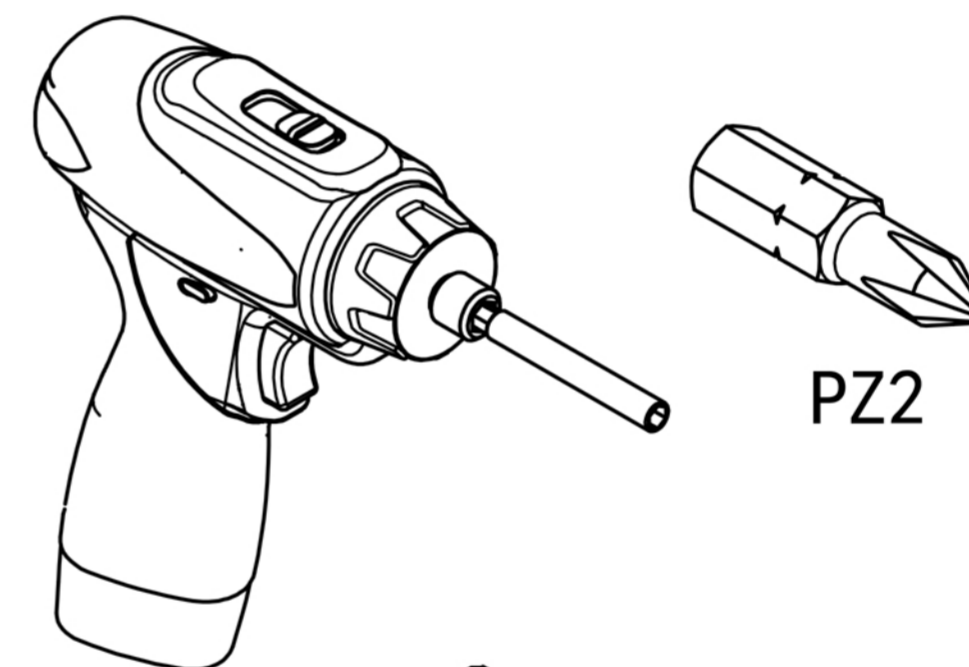

PZ2

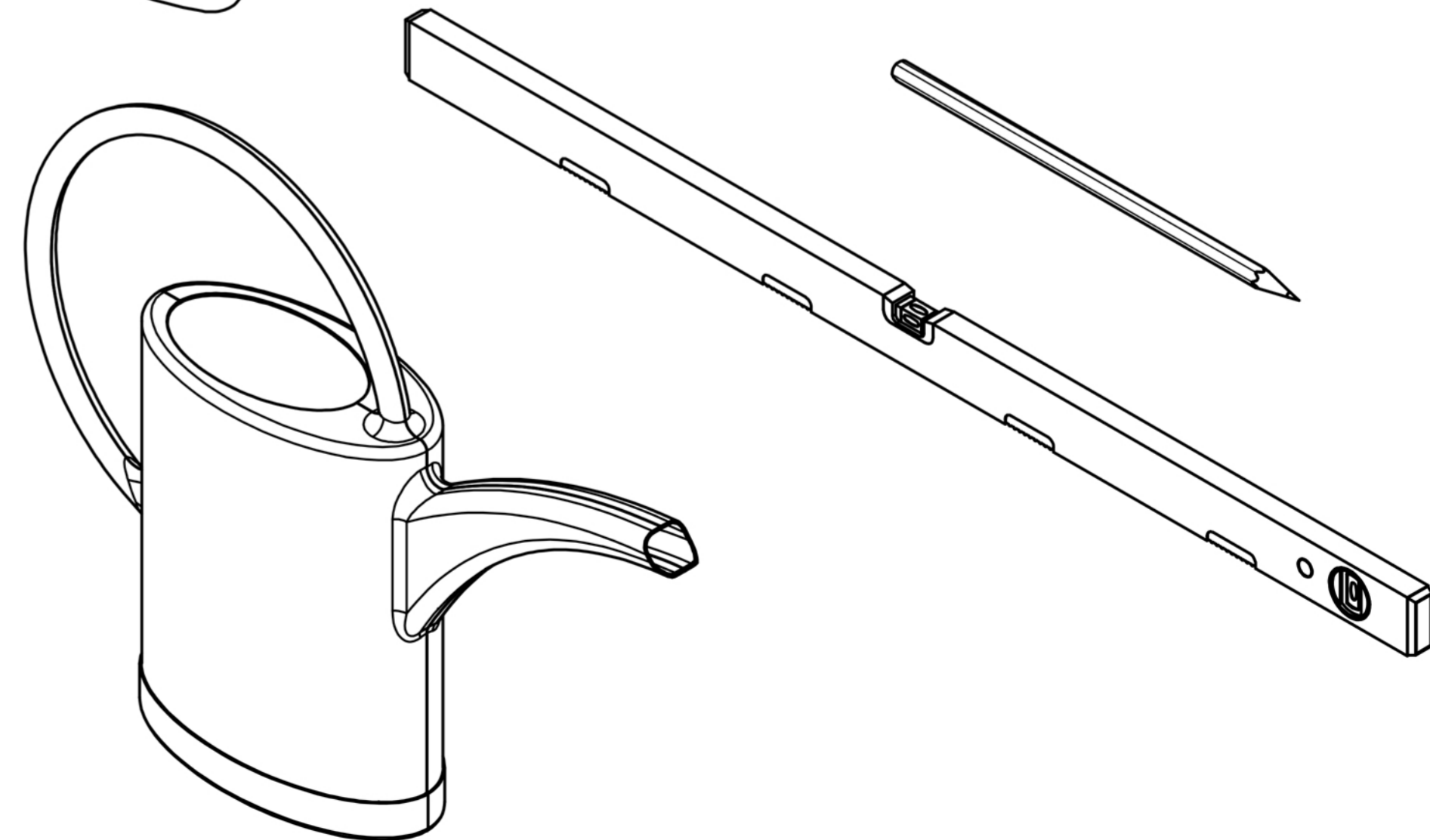

1

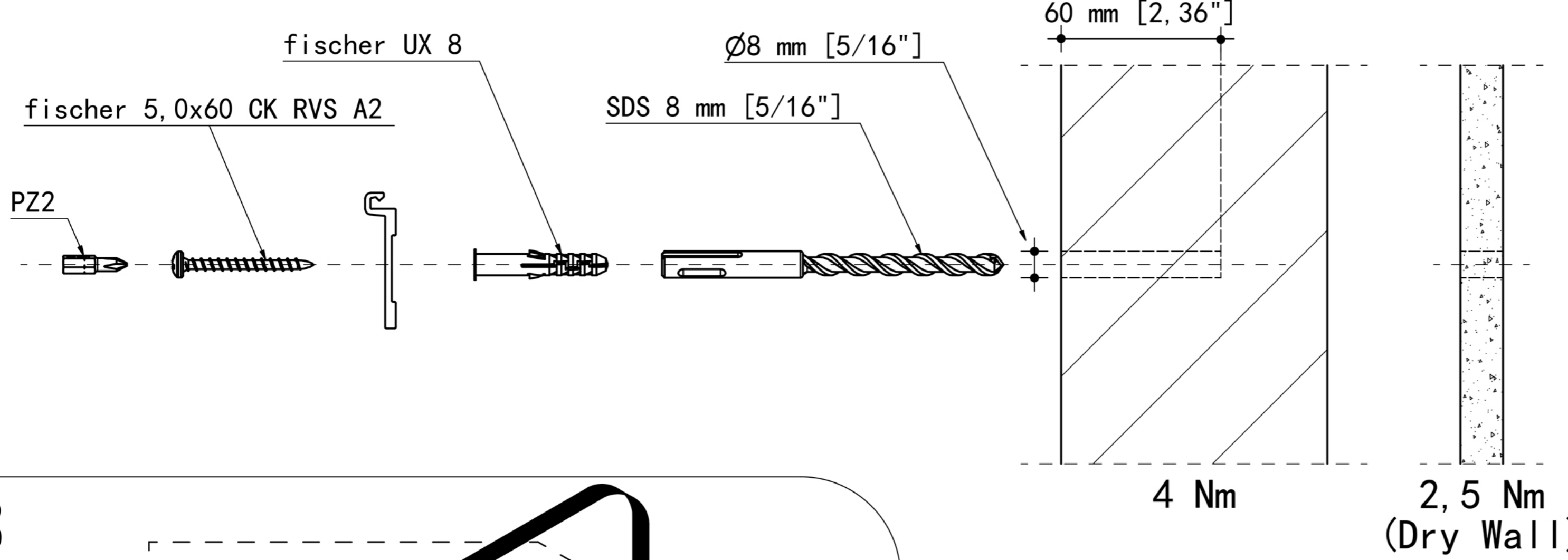

2

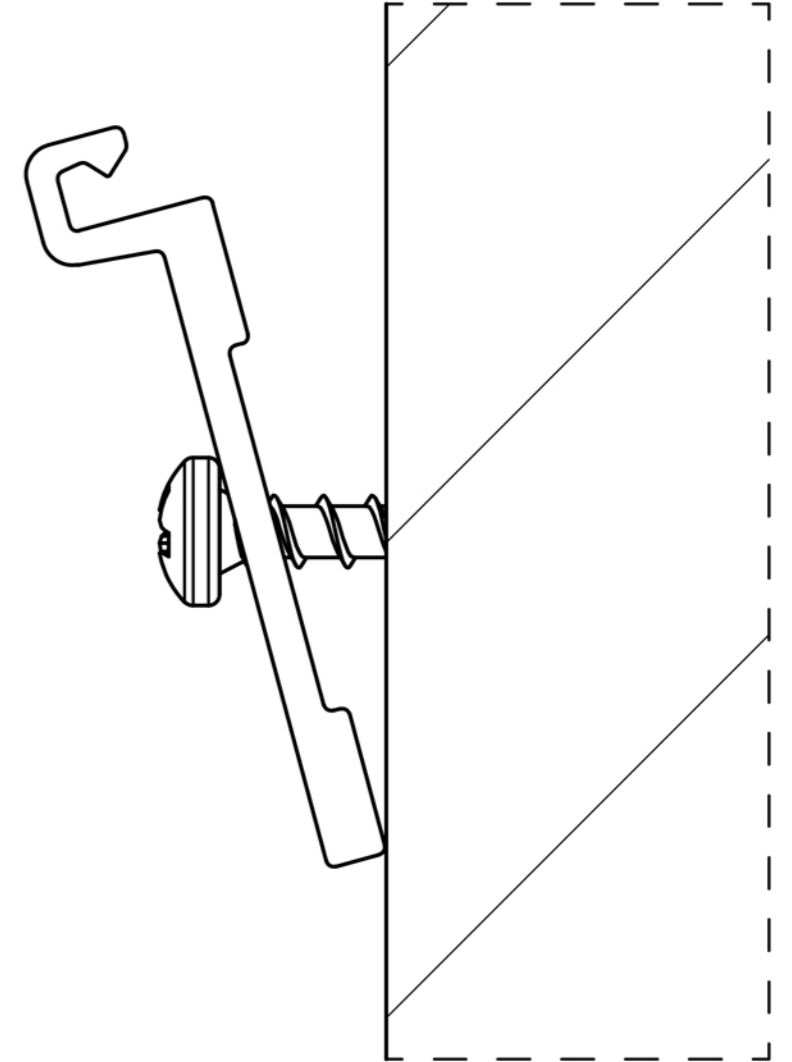

3

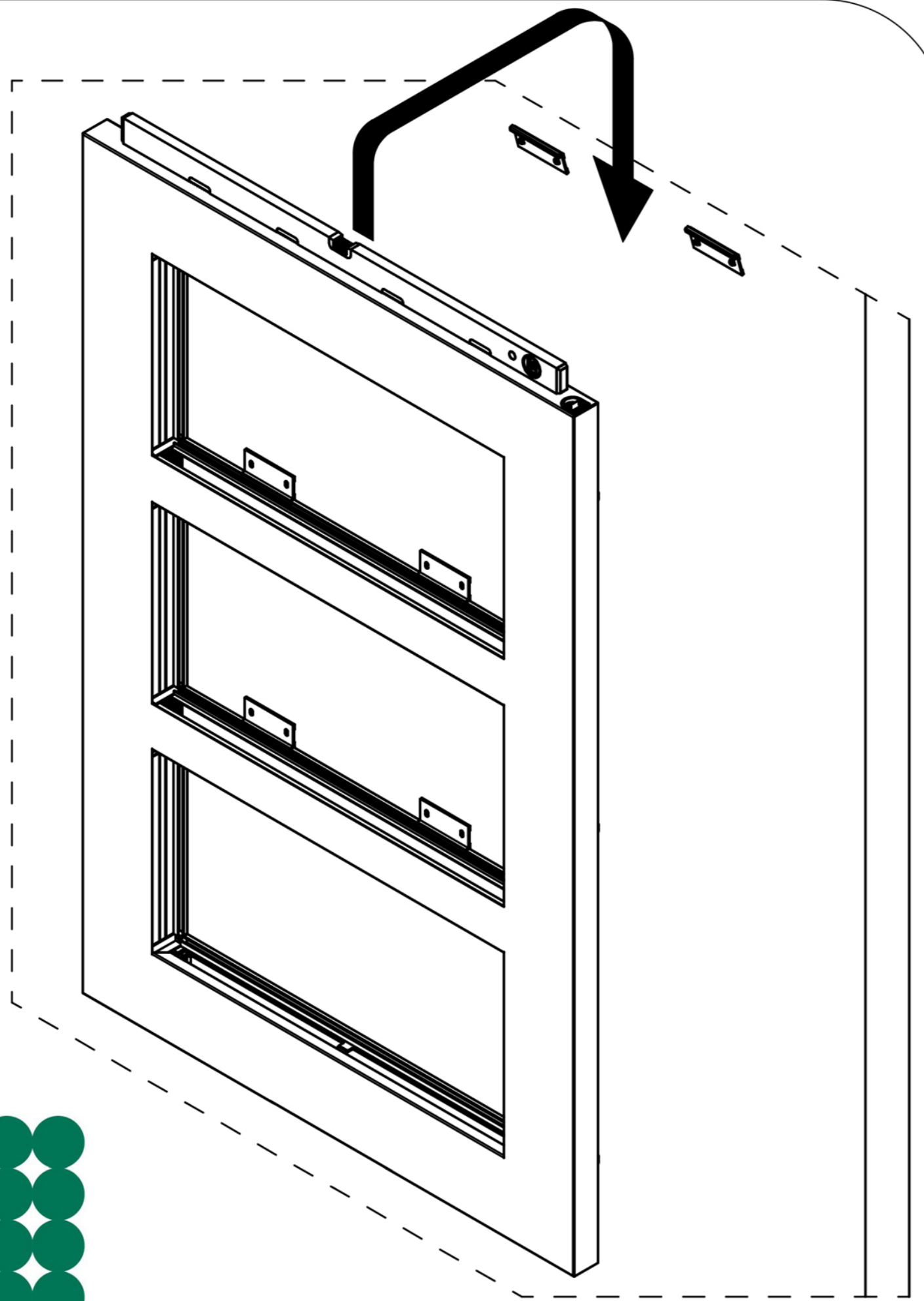

4

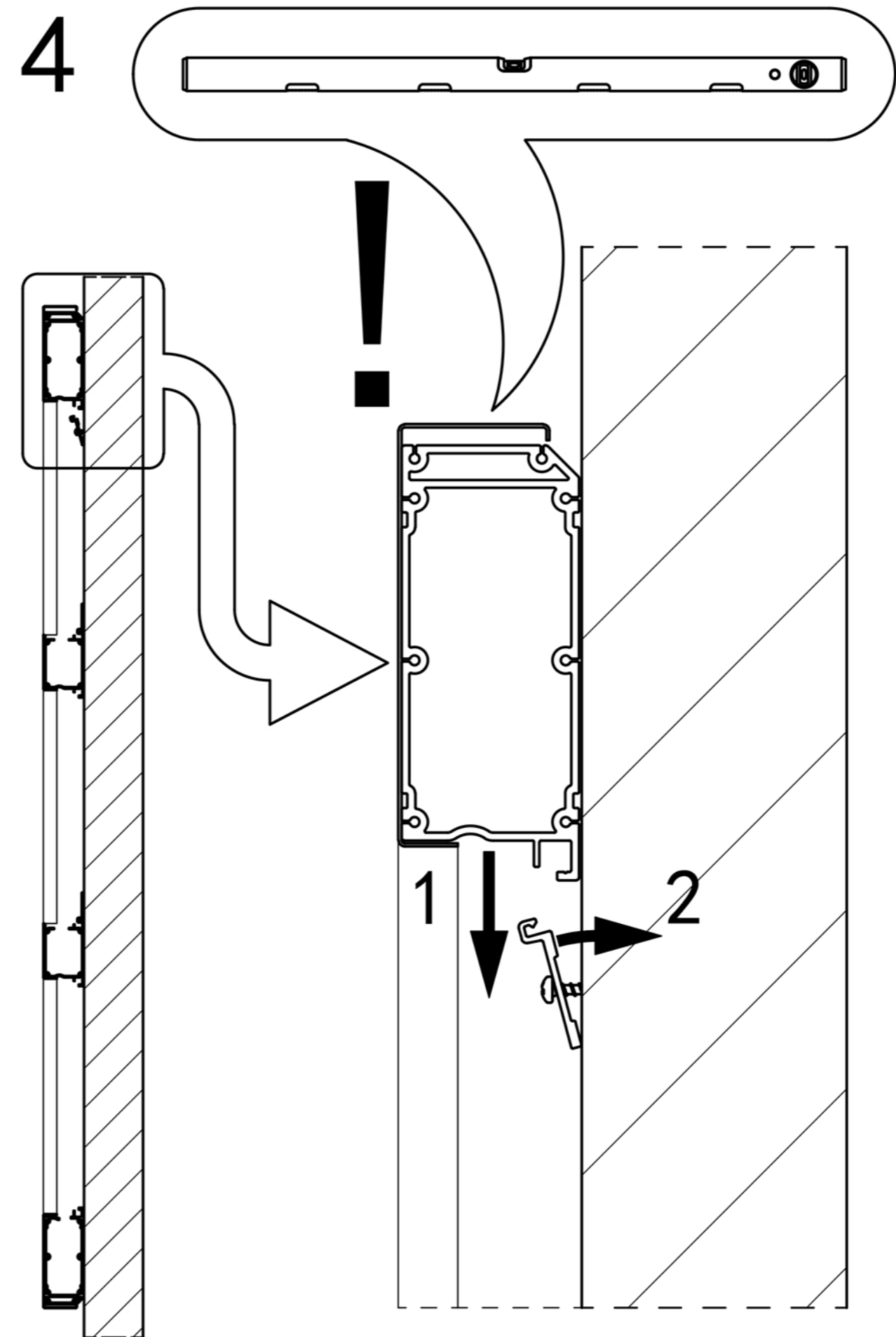

5

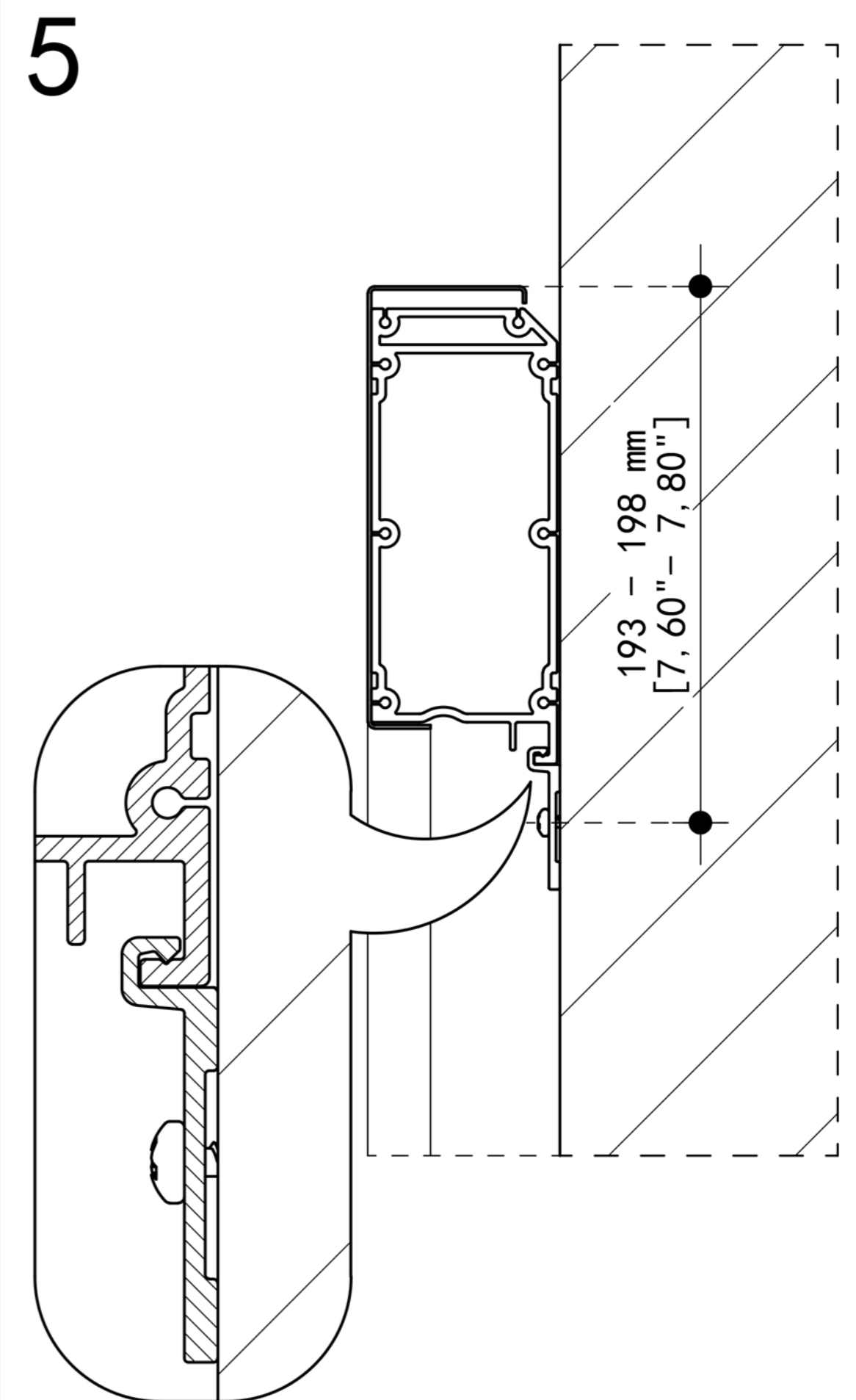

6

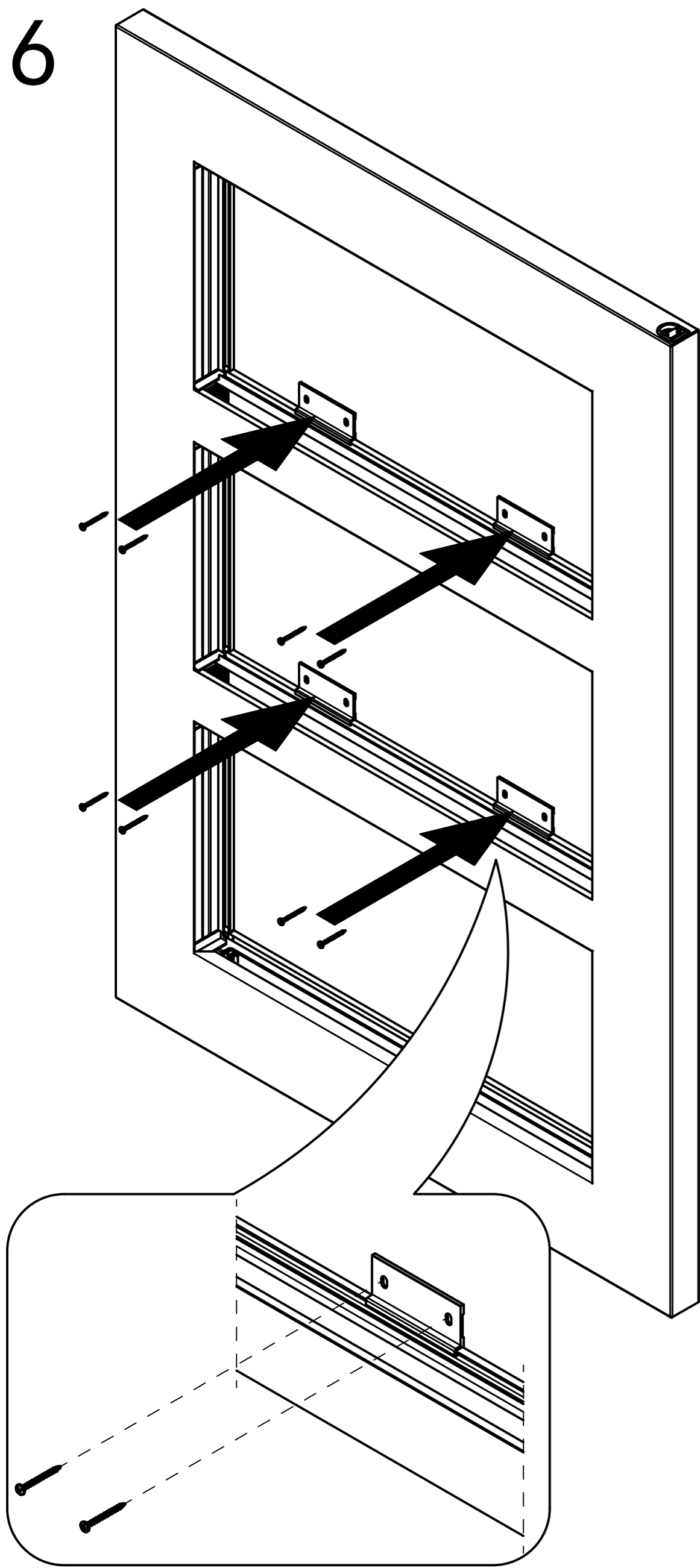

7

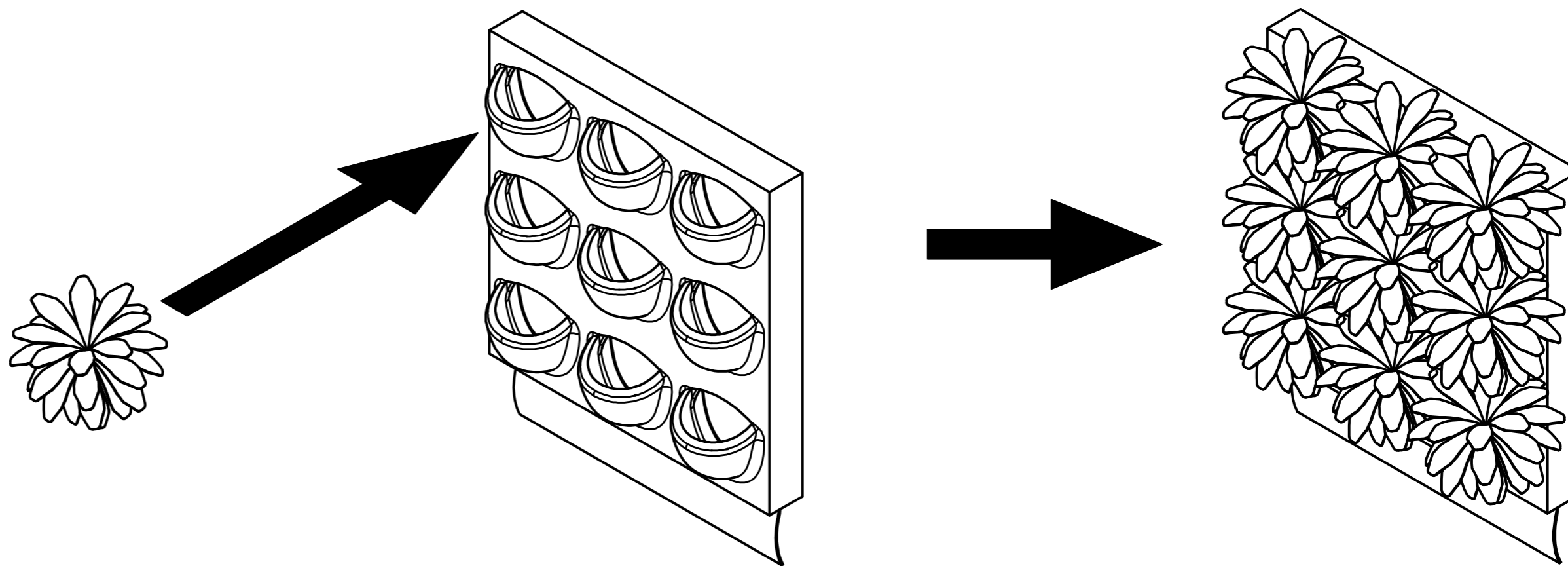

8

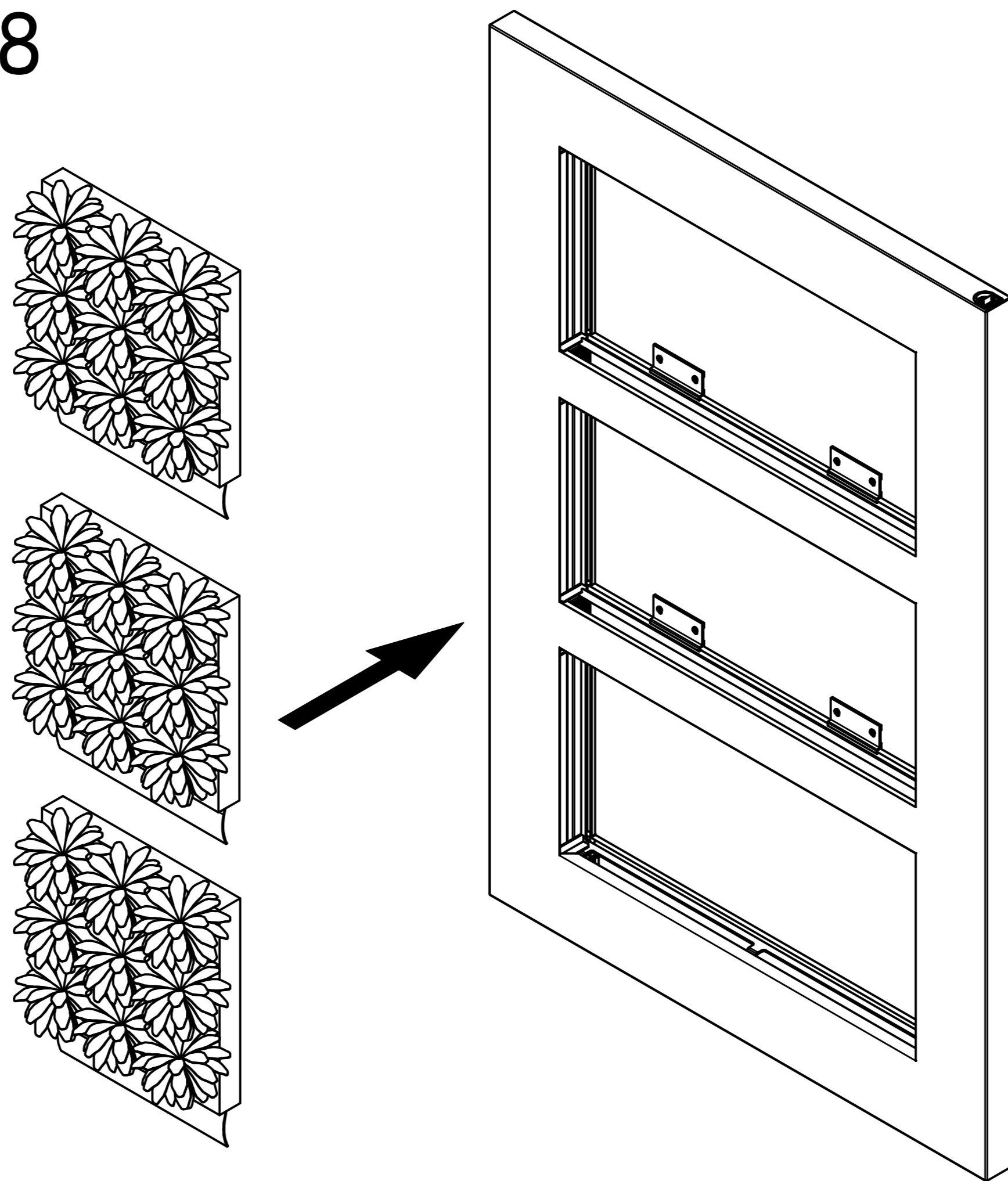

9

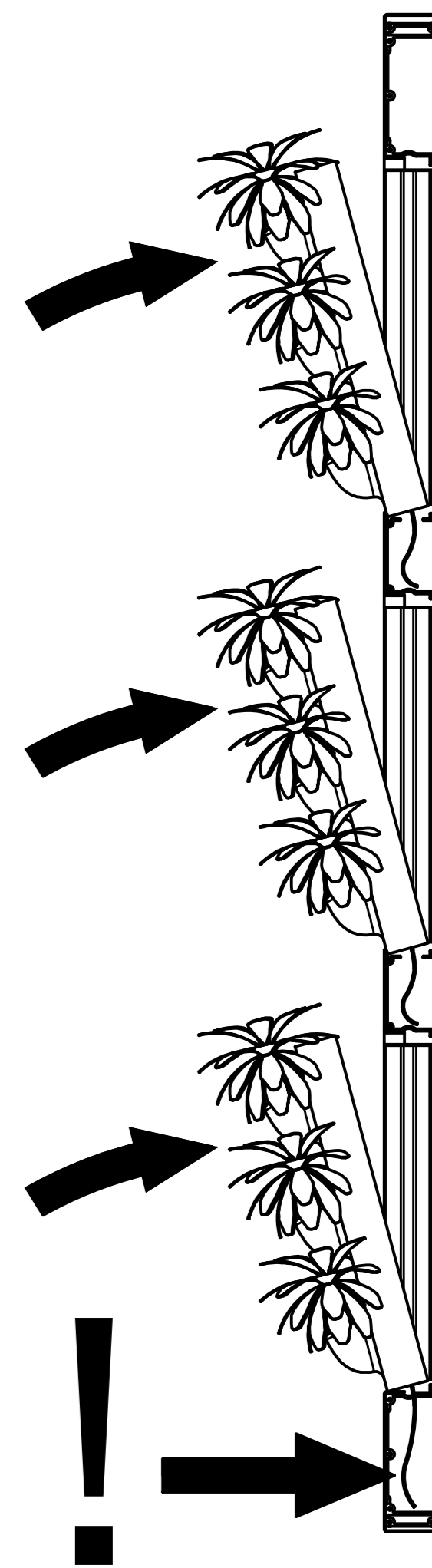

10

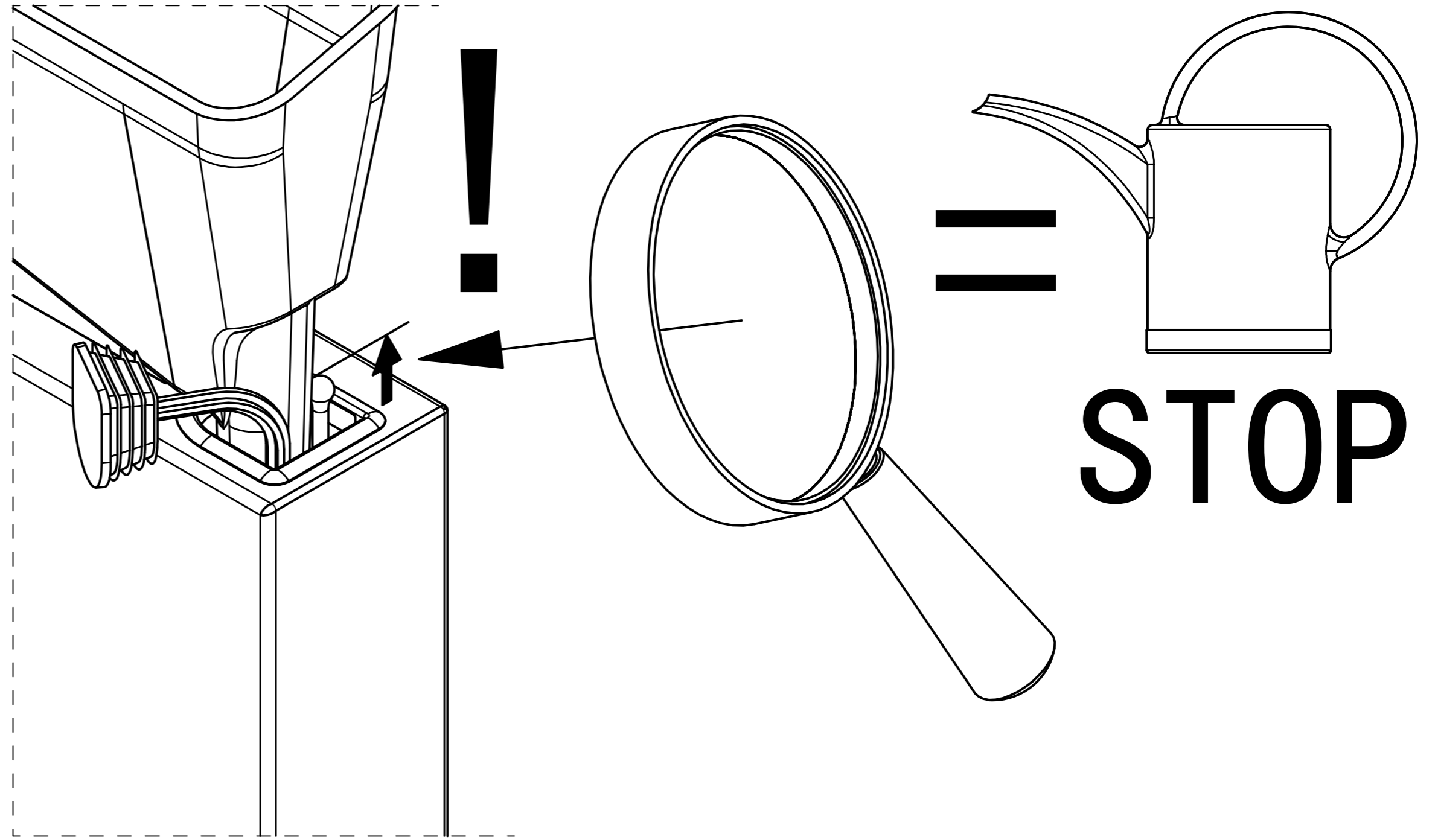
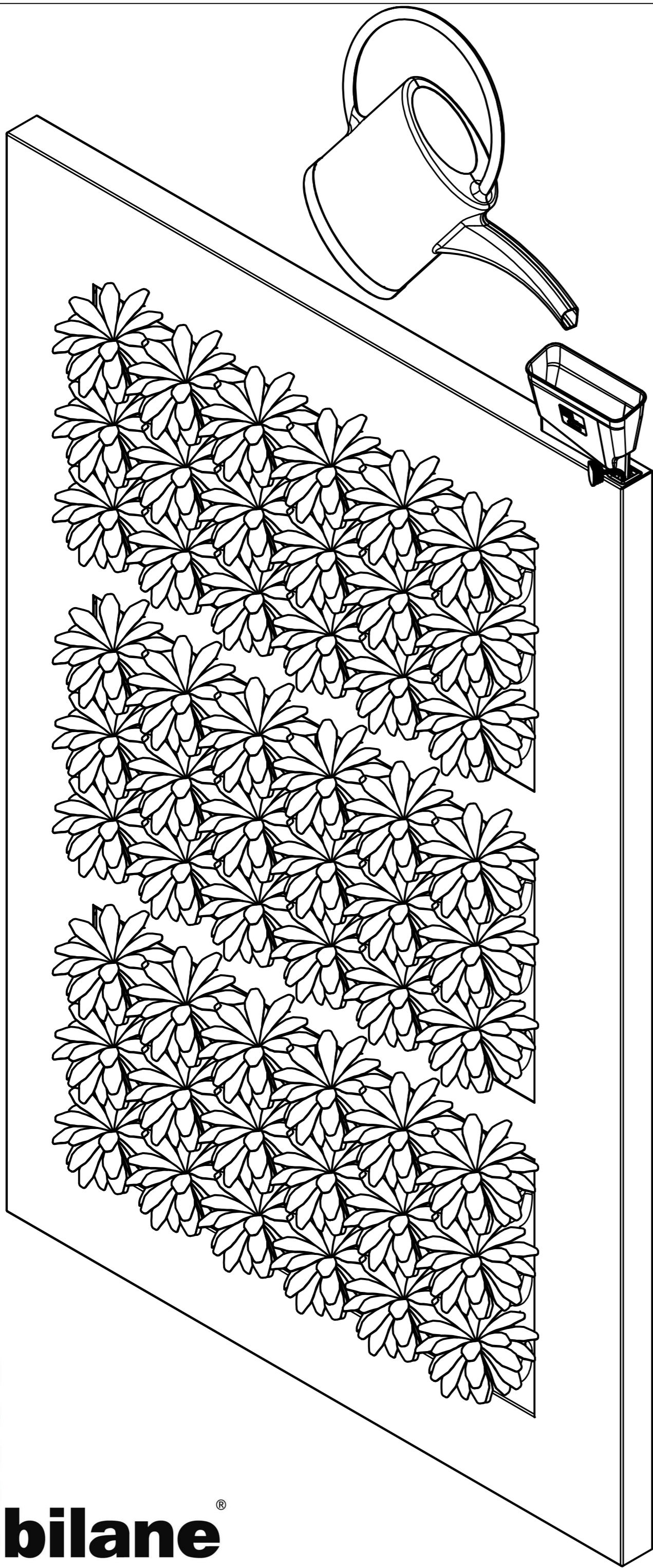

11

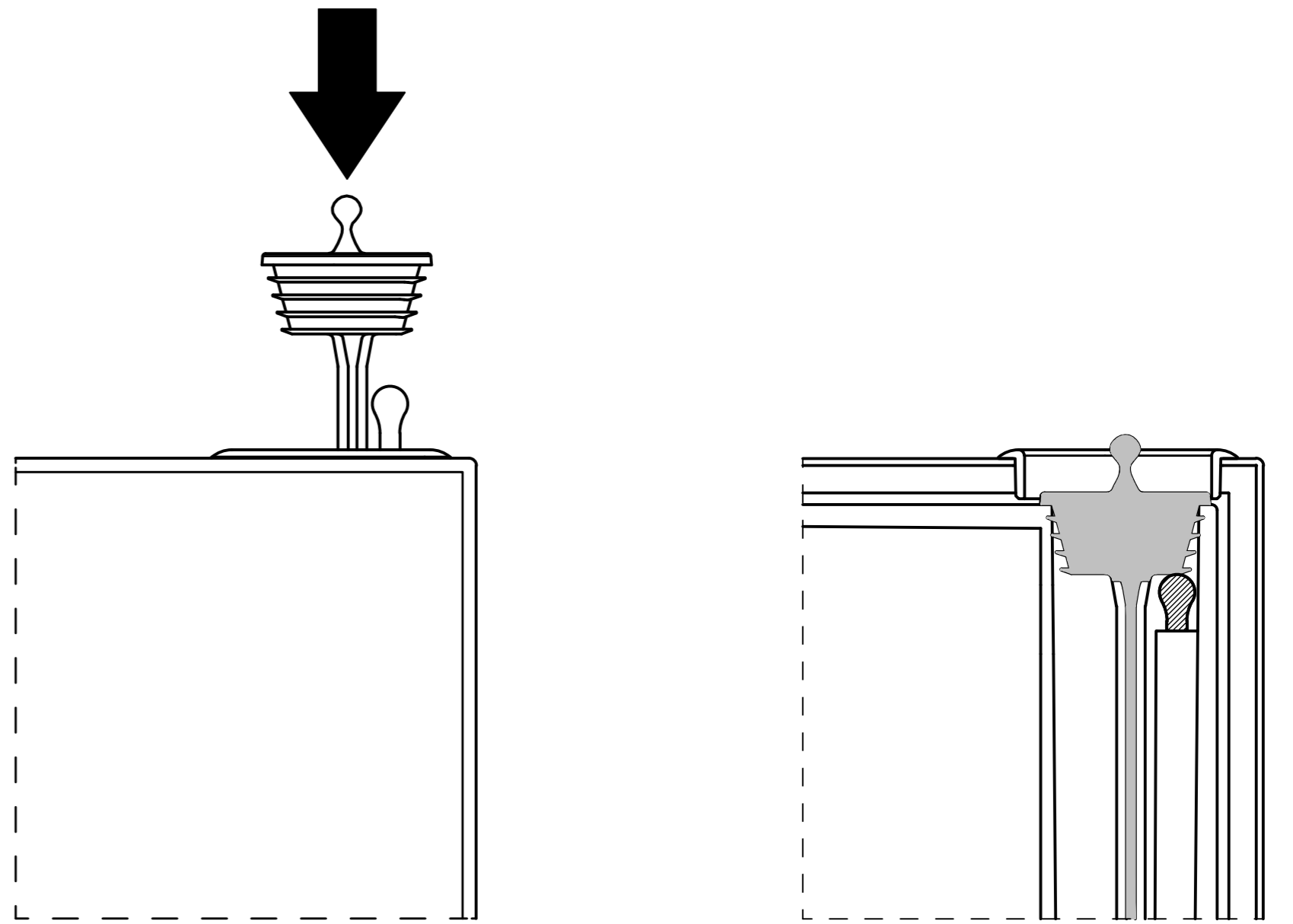

12

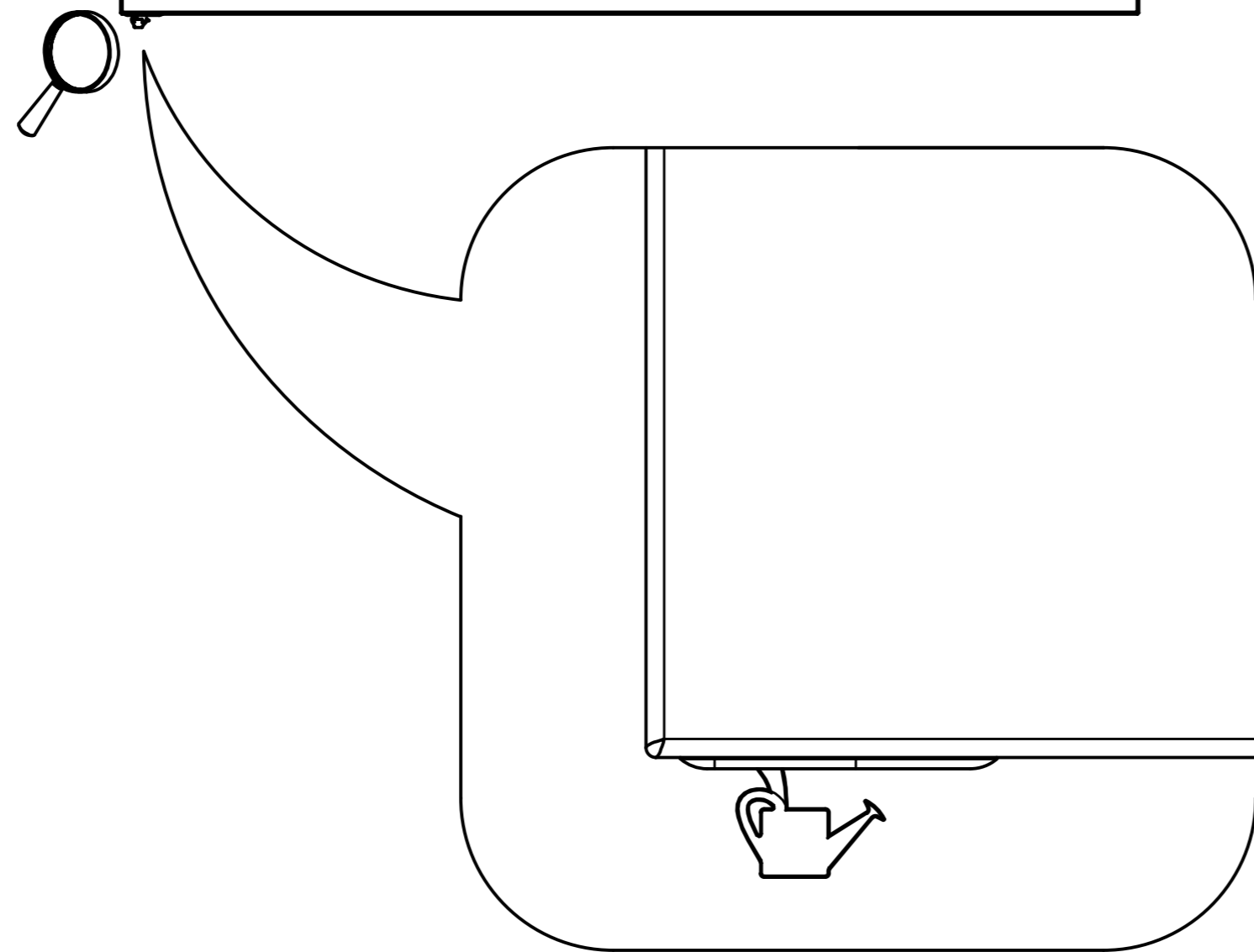
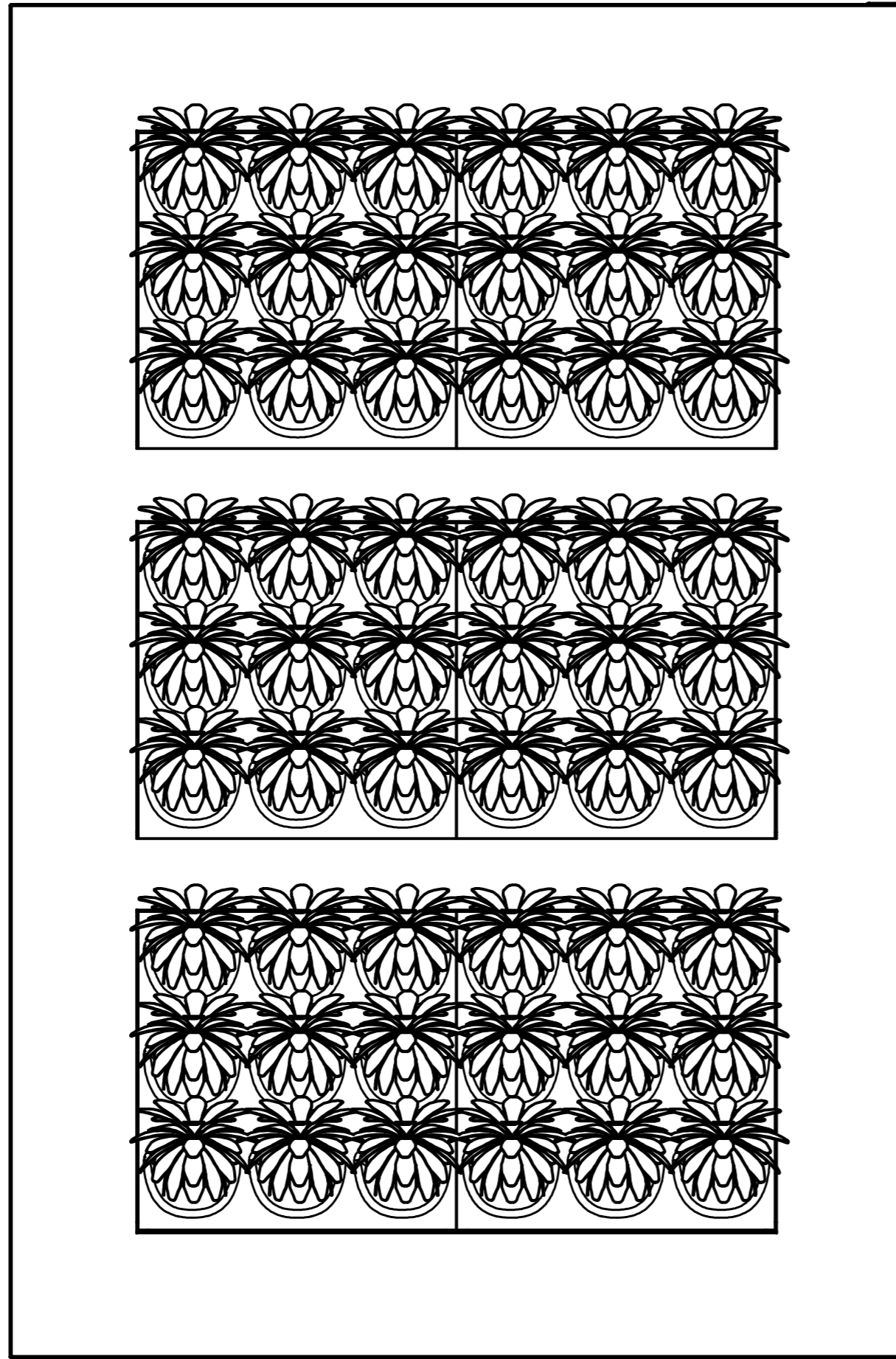

==

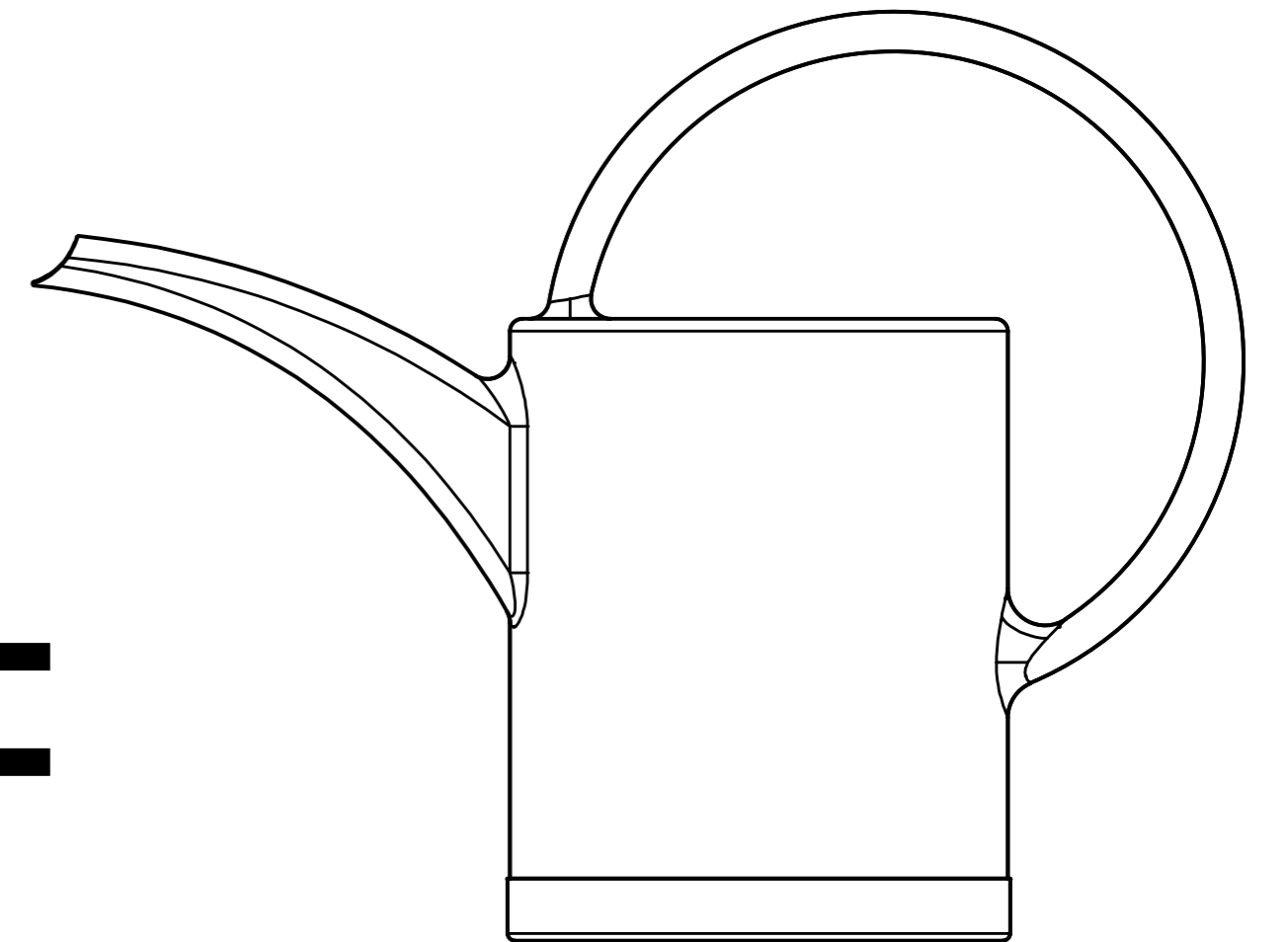

English

- As a control it is recommended to do the first filling of water prior to installing the Plant cassettes.
- Plant cassettes need to be removed in a horizontal movement, preferably holding the Plant cassette at diagonal corners.
- Water tank needs to be inspected annually; any root growth in the tank needs to be removed.
- Cleaning of the frame with standard alkaline cleaning soap, which is not a detergent or a solvent.
- Root ball of the plants need to be of sufficient moisture level upon planting

Deutsch

- Zur Kontrolle muss beim ersten Mal das System mit Wasser gefüllt werden bevor die Pflanzen-Kassetten eingesetzt werden.
- Die Pflanzen-Kassetten müssen in einer horizontalen Bewegung aus dem Rahmen genommen werden, wobei die Hände diagonal stehen müssen.
- Der Wasserbehälter muss jährlich überprüft werden, wobei mögliches Wurzelwachstum aus dem Wasserbehälter entfernt werden muss.
- Der Rahmen kann mit einem milden alkalischen Haushaltsreiniger gereinigt werden. Der verwendete Reiniger darf nicht ätzend sein und darf kein Lösungsmittel enthalten.
- Vor dem Einsetzen der Pflanzen sind die Wurzelballen zuvor ausreichend zu befeuchten.

Français

- La première fois, par mesure de précaution, remplissez le système d'eau avant de placer les modules à plantes dans le cadre pour vous assurer de son bon fonctionnement.
- Retirez les modules à plantes de façon horizontale du cadre en plaçant une main au coin supérieur droit et l'autre au coin inférieur gauche (en diagonal).
- Le réservoir d'eau doit être inspecté une fois par an et toutes éventuelles croissances de racines doivent être éliminées.
- Le cadre peut être nettoyé avec un produit d'entretien standard alcalin et à effet de saponification. Ne pas utiliser de produits détergents ni solvants.
- Au moment de la plantation, les mottes des plantes doivent être humides.

Nederlands

- Ter controle, dient de eerste keer het systeem met water gevuld te worden alvorens de Plant cassettes te plaatsen.
- Plant cassettes dienen in een horizontale beweging uit de lijst gehaald te worden, waarbij de handen diagonaal geplaatst dienen te worden.
- De waterbak dient jaarlijks gecontroleerd te worden, waarbij eventuele wortelgroei verwijderd dient te worden.
- De lijst kan schoongemaakt worden met een standaard schoonmaakmiddel dat verzepend werkt en alkalisch is. De gebruikte middelen mogen niet detergent zijn en mogen geen oplosmiddel zijn.
- Op moment van aanplanten dienen de wortelkluiten van de planten vochtig te zijn.

Italiano

- Per controllare, la prima volta si deve riempire il sistema con acqua e poi posizionare le cassette per piante.
- Le cassette per piante devono essere tolte dalla cornice con un movimento orizzontale, per cui le mani devono essere posizionate in diagonale.
- Il serbatoio dell'acqua deve essere controllato ogni anno, e l'eventuale crescita delle radici deve essere rimossa.
- La cornice può essere pulita con un prodotto standard per la pulizia che saponifica e che è alcalino. I prodotti utilizzati non devono essere detergent né solventi.
- Al momento della piantatura le zolle delle radici delle piante devono essere umide.

Español

- Para su control hay que llenar la primera vez el sistema con agua antes de colocar las cajas con plantas.
- Las cajas de plantas deben ser quitadas en un movimiento horizontal del marco para lo cual se deben poner las manos diagonalmente.
- Se debe controlar el depósito del agua anualmente durante el cual hay que quitar las eventuales raíces crecidas.
- Se puede limpiar el marco con un producto de limpieza estándar con efecto de jabón y con una reacción alcalina. Los productos utilizados no pueden ser detergentes y tampoco disolventes.
- En el momento de plantar los cepellones, con las raíces de las plantas, deben estar húmedas.